

EN



**User's manual
with installation instructions
for AUTOTERM marine fuel kit.**

Manufacturer: AUTOTERM LLC

Paleju 72, Marupe, Latvia, LV-2167

Warranty Department warranty@autoterm.com

Technical Support service@autoterm.com

www.autoterm.com

Table of contents

Introduction.....	3
1 General instructions and operating principle.....	4
2 Safety precautions.....	4
3 Installation of the fuel system.....	5
3.1.1 Fuel suction using a fuel suction hose.....	5
3.1.2 Fuel suction from an additional fuel tank.....	6
3.1.3 Installation of the fuel pump and the fuel supply line.....	7
3.1.4 Marine fuel kit installation.	8

Dear Customer!

Thank you for choosing AUTOTERM Marine fuel kit! We are doing everything to make this product meet your requirements, so its quality satisfies every customer.

Introduction

This manual is intended for organizations that specialize in installation and maintenance of heaters AUTOTERM AIR, AUTOTERM FLOW and users of the product after installation. The document covers main rules of installation of the product on different small maritime transport (e.g. yacht, boat, cutter), function tests of the product after installation and basic maintenance procedures to ensure reliable operation of the heater.

Please read this manual before installing and/or operating the heaters with Marine fuel kit. This manual contains needful information in order to use this product correctly. Disregard of these instructions can void the warranty of the product, lead to damage of product and/or property and be a risk to health.

1 General instructions and operating principle

The AUTOTERM Marine fuel kits are designed to be used only with AUTOTERM AIR and AUTOTERM FLOW heaters.

This fuel kit meets the requirements of ISO 7840 – MARINE FUEL A1 standard. It applies to hoses for small craft with permanently installed fuel systems. It does not apply to hoses entirely within the splash well at the stern of the craft connected directly to an outboard engine.

This fuel kit is installed and used in place of standard fuel kit supplied with heaters.



Installation of the heater and its components **must be carried out by specialized organizations** approved by AUTOTERM. Installation of the heater must be carried out **only by certified specialists** in accordance with the installation instructions.



If the heater is handled and/or installed improperly, there is a **possibility of a fire hazard and damage of property** because fuel and electrical components are being used. That is why all safety precautions and installation instructions must be observed.

2 Safety precautions



- Disable [switch off] the heater, when the vessel is being re-fuelled.
- **The installation arrangement must exclude the possibility of contact of the exhaust pipe with the air intake, fuel pipe, or other flammable objects.**
- The vessel where the heater is installed must be equipped with a fire extinguisher.



- **Electric wiring, the air intake, and the fuel pipe must be protected from contact with sharp edges of vessel structures.**



- For safety reasons, contact the service shop to troubleshoot the heater if it fails to launch two times in a sequence.
- In case of faults in the operation of the heater, contact specialized repair organizations authorized by AUTOTERM.

If the consumer fails to follow the requirements above, the warranty of the heater becomes null and void.

3 Installation of the fuel system.



Do not operate the heater using biofuel.

Use only diesel fuel standard EN590 for diesel operated heaters and gasoline EN 228 for gasoline operated heaters, depending on the ambient temperature.

Act as instructed on Fig.1 and Fig.5 to install the fuel system. The fuel pump and the fuel supply line must be protected from heating.



Do not take fuel from fuel filter or it's casings, because doing so causes a leak of fuel.



Do not take fuel from the fuel line between the fuel filter and fuel pump of the vessel's engine, the return line of the engine or after the high-pressure pump of the vessel.

Heater is not designed to work with pressure over 0.2 bar.



Recommended length of the fuel line is 5m. It is advised not to cut fuel lines if possible to shorter lengths. Distance between fuel tank and fuel pump should not exceed 1m and distance between fuel pump and the heater should not exceed 4m (see Fig.1 and Fig.5)

3.1.1 Fuel suction using a fuel suction hose.



Before installing a fuel suction hose in a fuel tank of the vessel, make sure that the fuel level is high enough to ensure operation of the heater, and low enough to easily remove the fuel tank, if needed.

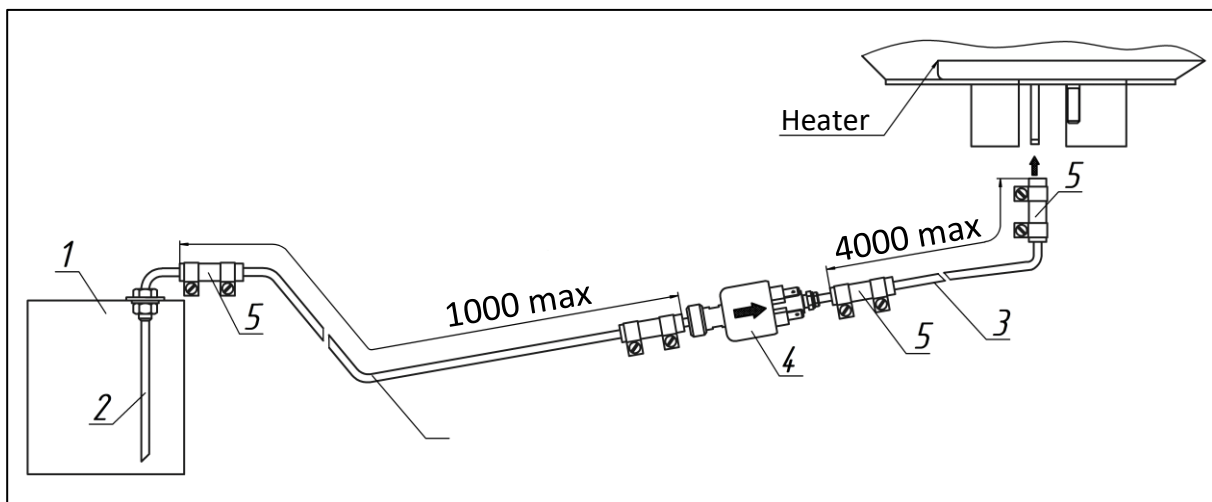

Fig. 1 - Example of fuel supply to the heater with fuel suction hose

Fuel is taken directly from the fuel tank of the vessel or an additional tank. Drill a hole $\text{Ø}16\text{mm}$ in the fuel tank to install a fuel suction hose. When drilling the hole in the fuel tank, follow safety precautions that should be observed when working with a transport, which is filled with fuel or explosive substance.

If needed, cut the immersible tube of the fuel suction hose shorter before installation. Its bottom end must be located about 10-15 mm

above the bottom of the tank, or at the height to provide fuel for the engine in the fuel tank at any time. The cut at the end of the fuel suction hose must be made at a 45° angle to the axis of the tube. Remove all burrs from the cut after the work is done.

Install the fuel suction hose in the fuel tank as per Fig.2a. Install the special washer of the fuel suction hose in the tank hole as per Fig.2b. Apply a fuel-proof sealant on the threaded surface of the fuel suction tank to properly seal the connection between the fuel suction hose and the fuel tank.

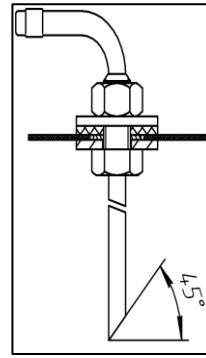

Fig. 2a – Installation of the fuel suction hose

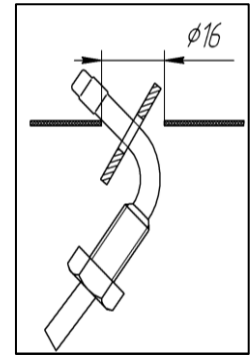

Fig. 2b – Installation of the washer.



Never install the suction hose on the side of the fuel tank. It must be installed on the top side of the fuel tank.

3.1.2 Fuel suction from an additional fuel tank

Consider convenience of fuelling, when installing the fuel tank (Fig.3). Install the fuel tank in such a way that the amount of fuel and its potential leaks from the inlet, fuel suction nozzle or connections can be visually controlled.



When filling the fuel tank, be careful not to spill any of the fuel on the exhaust system, wiring or other objects, which can be damaged due to their contact with fuel.



Fuel tank must be installed with its wide side perpendicular to the direction of the movement of the vessel (see Fig. 3).

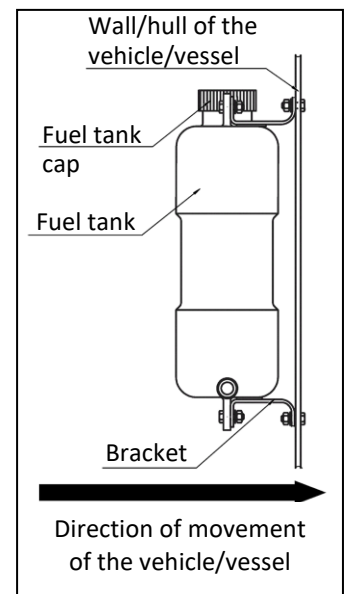

Fig. 3 Installation of the fuel tank

3.1.3 Installation of the fuel pump and the fuel supply line.

The fuel pump is connected to the heater through its own harness and supplies fuel depending on the required heat capacity to the combustion chamber of the heater. The fuel pump is operated by electrical impulses sent by the control unit. When running, the fuel pump makes characteristic metallic clicking noise.

It is recommended to install the fuel pump close to the fuel tank (distance should not exceed 1 meter (see Fig.1 and Fig.5)) and below the low level of fuel in the fuel tank, but not lower than 70cm of the minimal fuel level (see Fig.5, point a)). But the height between the fuel pump and the heater cannot be greater than 1,5 meters (see Fig.5, point b)). Fuel pump should be positioned with a slight angle pointing upwards (see Fig.4)

If for some reason sealing of the fuel pump is compromised, it is advised to install the fuel pump lower than the heater in order to avoid leaks and overflowing the heater with fuel due to gravity.

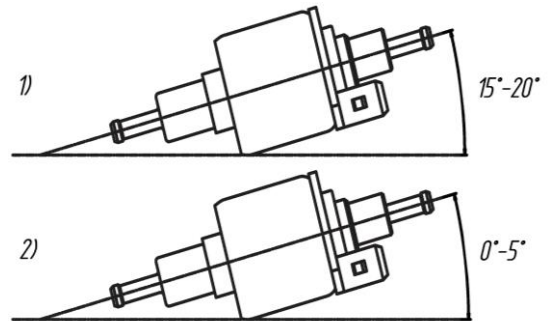

Fig. 4 – Installation angle of Advers fuel pump (1) and Thomas Magnete (2) fuel pump.



Remember to properly bleed the “silent” TH11 fuel pump. If it’s not properly bled it will be as loud as a standard fuel pump.

To bleed it start the heater and position the fuel pump with its outlet upwards till there are no air bubbles in the fuel line and only then secures the fuel pump in its recommended position.

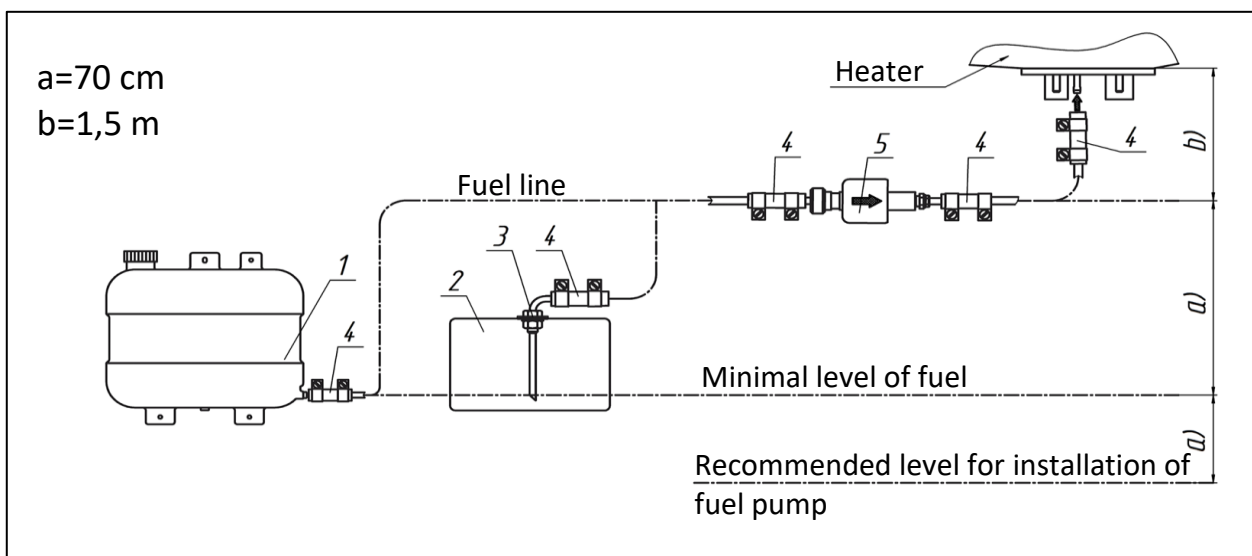

Fig. 5 – Height position of the fuel pump in the fuel system

3.1.4 Marine fuel kit installation.

1. Assemble the shut off valve[5] and both fittings[7] together. Put copper O-rings[6] at the fitting thread side
2. Put rubber sleeves[8] with clamps[4] to the both fittings.
3. Connect the fuel pump incoming line to the shut off valve outgoing side sleeve. Tighten sleeve clamps.
4. Mount fuel tank or fuel pick up tube (included in the heater installation kit) according Fig.2 or Fig.3
5. Fasten the fuel pump[3] to the surface with a clamp. Don't overtake 1m maximum distance from the fuel tank[1].
6. Connect fuel pick up tube/fuel tank with shut off valve using 1m copper pipe[9] piece and sleeves[8]. Push copper pipe[9] to the sleeve[8] as possible deep to avoid air bubbles occurrence during operation. Do not cut the pipe. Fasten copper fuel pipe[9] to surface with p-clamps each 30 centimetres
7. Connect 4m copper pipe piece[9] to the fuel pump outgoing side sleeve[8].
8. Fasten fuel pipe to the surface. It is preferable to lay the fuel supply line on a straight line and with a small inclination upwards in the direction of the heater. The fuel supply line should be fastened each 30cm to prevent sagging, prevent effects of vibrations and avoid fractures. Do not cut the copper pipe.
9. Connect fuel pump wiring harness to the fuel pump socket. Check if the shut off valve[6] is open. Start the heater several times until the fuel displaces air from the fuel pipe.
10. Put rubber sleeve[8] with clamps[4] to the heater[2] fuel intake pipe and connect the end of 4m copper pipe[9] to the heater[2]. Push copper pipe to the sleeve[8] as possible deep to avoid air bubbles occurrence during operation
11. Retighten all clamps[4].

Start the heater[2] and check fuel lines for leakage during operation.

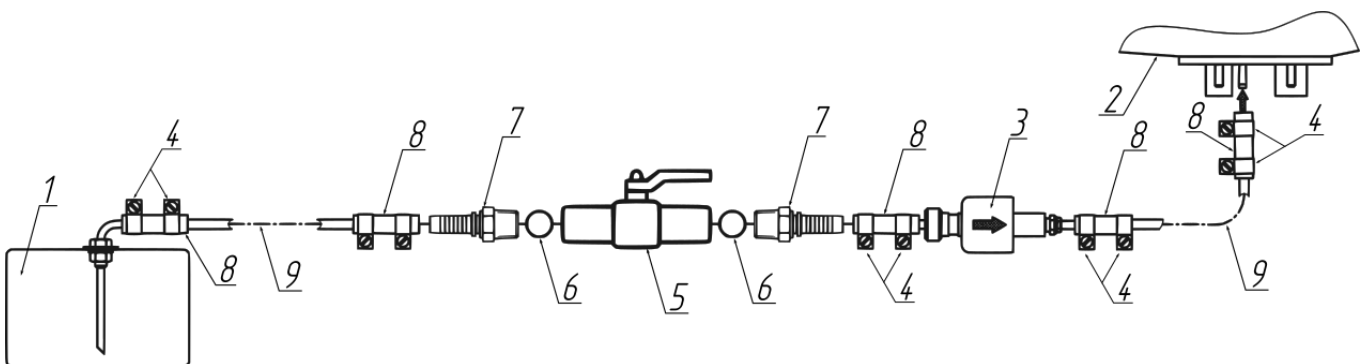

Fig. 6 – Marine kit assembly

- | | | |
|----------------|---------------------|-----------------------|
| 1 – Fuel tank; | 4 – Clamp; | 7 – Fitting; |
| 2 – Heater; | 5 – Shut off valve; | 8 – Sleeve; |
| 3 – Fuel pump; | 6 – O-ring gasket; | 9 – Copper fuel pipe. |